

Compact CHP ready for connection, mainly consisting of

- serially manufactured Industrial-Gas-Otto-engine
- air-cooled synchronous generator
- waste-gas heat exchanger integrated in primary cooling circuit
- Oxikat integrated in waste-gas heat exchanger (optional)
- oil reservoir with automatic oil feeding
- control cabinet with programmable controller and operating unit
- gas train

Integrated heat exchanger basket, mainly consisting of

- expansion tank in motor circuit and mixture circuit
- relief valve in motor circuit, mixture circuit and heater circuit
- filling valves, cleanout valves and exhaust valves
- plate heat exchanger
- pumps for motor circuit, mixture circuit and heater circuit
- 3-way mixing valve for return temperature increase

Water and gas connections are executed with compensators. All water-side connections are directed upwards above the heat exchanger basket.

Motor and generator are connected through a pluggable elastic metal-plastics coupler to compensate radial offset, axial offset or angular offset. It is mounted on a framework vibration-cushionedly.

Furthermore the framework is uncoupled through oscillation decoupling elements.

The control cabinet is executed as a separate unit. All regulation and control functions as well as control elements are part of the control cabinet. Assisted by a menu-navigated touch-screen performance data and state data could be readed and adjusted easily.

The drive of the CHP is caused by a water-cooled, supercharged Otto-Gas-Engine. It is a stationary engine designed for permanent operation. A microprocessor-controlled ignition ensures an optimal adaption of the ignition point and the ignition energy to the gas quality (methane number).

Besides an exceedingly high electrical efficiency, a double-staged mixture cooling, including a low temperature circuit and a high temperature circuit, leads to an ideal usage of thermal power from the mixture heat.

The oil level control is carried out by a sight glass with oil level deficit indication, which is connected with the oilpan.

Engine data		Hz	50	Engine utilities	
Mixture cooling to RPM	°C	50		Lubricate consumption	g/kWh 0,5
ISO standard power (mech.)	1/min	1500		Filling capacity lubricant min./max.	l 60/90
Air ration (Lambda)	kW	384			0
Arrangement of cylinders	λ	1,47		Filling capacity cooling water	l 23
Number of Cylinders		V		Operating pressure (max.)	bar 3
Bore		12		Cooling water recirculated quantity	l/min 554
Stroke	mm	128		Cooling water temperature min.	°C 80
Swept volume	mm	142		Cooling water temperature max.	°C 88
	l	21,93		Balance (inflow/exit, max.)	K 6
Direction of rotation (look on balance wheel)		left		Mixture inflow temperature after damper max.	°C 50
body of balance wheel		SAE 1		Mixture cooling water, inflow temperature	°C 45
tooth rim with number of teeth	Z	160		low temperature circuit (max.)	
compression ratio	ε	12,0 : 1		Mixture cooling water recirculated quantity	l/min 86
average effective pressure	bar	13,87		low temperature circuit (max.)	
average piston speed	m/s	7,1		Mixture cooling water inflow temperature	°C 85
				high temperature circuit (max.)	
				Mixture cooling water recirculated quantity	l/min 216
				high temperature circuit (max.)	
Power data		Hz	50	Efficiencies	
Load	%	100		Electrical	% 38,8
Ignition timing	degree	18		Mechanical	% 40,3
ISO standard power (mech.)	kW	384		Thermal	% 45,2
Electrical Power	kW	370		Total (el. + th.)	% 84,0
Cooling water heat	kW	206			
Mixture heat (low temperature circuit)	kW	16		Power number	0,86
Mixture heat (high temperature circuit)	kW	41			
Waste gas heat up to 180 °C	kW	184			
useable thermal power at 180 °C	kW	431		Mass flows and volume flows	
radiant heat of module (max.)	kW	62		Combustion air mass flow	kg/h 1.743
nominal power	kW	953		Combustion air volume flow	m³/h 1.472
Fuel consumption (mech.)	kWh/kWh	2,48		Supply air volume flow	m³/h 14.422
Fuel consumption (el.)	kWh/kWh	2,58			
Temperatures and pressures				Combustible mass flow	kg/h 195
Waste gas temperatur after turbine	°C	480		Combustible volume flow	m³/h 159
exhaust back pressure	mbar	40		Waste gas mass flow, wet	kg/h 1.938
				Waste gas mass flow, dry	kg/h 1.802
Heating water return temperature (max)	°C	70		Waste gas volume flow, wet	m³/h 1.496
Heating water flow temperature (max)	°C	90		Waste gas v olume flow, dry	m³/h 1.315
Pressure decrease heating circuit (max)	mbar	150			
				Heating water volume flow (max.)	m³/h 25
maximum backpressure at the air intake	mbar	15		Technical basic conditions	
Emission value at 5% residual oxygen				Power conditions acc. To DIN-ISO-3046	
NOx	mg/Nm³	< 500		Norm conditions: air pressure: 1000 mbar	
CO (without catalyst)	mg/Nm³	< 1000		Air temperature: 25 °C or 295 K, rel. Humidity: 30%	
CO (with catalyst)	mg/Nm³	< 300		Gasquality accorcng "2G TA 04 Gas"	
HCHO (formaldehyde without catalyst)	mg/Nm³	< 60		All data are related to full load engine running at denoted	
HCHO (formaldehyde with catalyst)	mg/Nm³	< 40		media temperatures and are subject to technical advancements.	
NMHC	mg/Nm³	< 150		Equipment as well as installation systems have to meet all	
				technical instructions of 2G.	

Generator data

Manufacturer		Leroy Somer
Type		LSA 47.2 L9 / 4p
Power at Cos φ = 0,8	kVA	462,5
Voltage	V	400
Frequency	Hz	50
Rated speed	1/min	1500
Nominal current at Cos φ = 0,8	A	668
Cos φ		0,8 - 1
Efficiency (full load) at Cos φ = 1	%	96,40
Efficiency (full load) at Cos φ = 0,8	%	95,00
Reactance X"d	%	12,60
Reactance Xi = X2	%	14,50
Mass moment of inertia	kg m ²	8,32
Stator circuit		star
Ambient air temperature	°C	40
Protection class		IP 23
Cos φ has to be between 0,8 and 1,0 within the complete range of capacity.		

Main dimensions and weights

Module:			
Length (L):	mm	3.950	
Height (H):	mm	2.208	
Width (B):	mm	1.500	
Weight (approx.):	kg	5.900	
Control cabinet			
Height (H)	mm	2.000	
Width (B)	mm	800	
Depth (T)	mm	600	
Weight (approx.):	kg	200	
Power switch cabinet			
Height (H)	mm	2.000	
Width (B)	mm	600	
Depth (T)	mm	500	
Weight (approx.):	kg	150	

Modul:

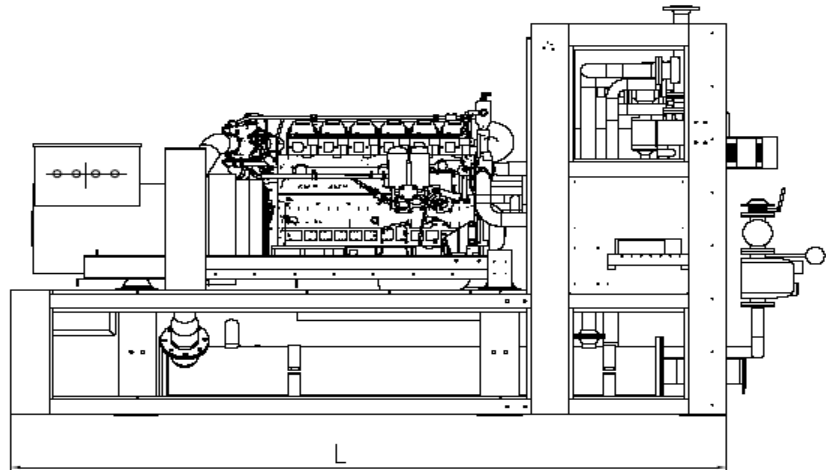
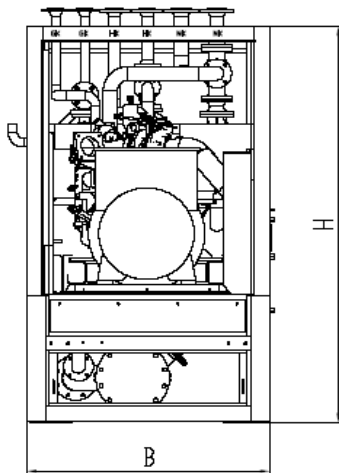

Control cabinet:

Power cabinet:

