

Illustration: may differ from specified module

Compact CHP ready for connection, mainly consisting of

- serially manufactured Industrial-Gas-Otto-engine
- air-cooled synchronous generator
- waste-gas heat exchanger integrated in primary cooling circuit
- oil reservoir with automatic oil feeding
- control cabinet with programmable controller and operating unit
- gas train

Integrated heat exchanger basket, mainly consisting of

- expansion tank in motor circuit and mixture circuit
- relief valve in motor circuit, mixture circuit and heater circuit
- filling valves, cleanout valves and exhaust valves
- plate heat exchanger
- pumps for motor circuit, mixture circuit and heater circuit
- 3-way mixing valve for return temperature increase

Water and gas connections are executed with compensators.

Motor and generator are connected through a pluggable elastic metal plastics coupler to compensate radial offset, axial offset or angular offset. It is mounted on a framework vibration-cushionedly. Furthermore the framework is uncoupled through oscillation decoupling elements.

The control cabinet is executed as a separate unit. All regulation and control functions as well as control elements are part of the control cabinet. Assisted by a menu-navigated display performance data and state data could be readed and adjusted easily.

The drive of the CHP is caused by a water-cooled, supercharged Otto-Gas-Engine. It is stationary engine designed for permanent operation. A microprocessor-controlled ignition ensures an optimal adaption of the ignition point and the ignition energy to the gas quality (methane number).

The lambda control is carried out without lambda probe over the combustion chamber temperature, which is determined with the aid of a thermocouple in the cylinder. The combustion chamber temperature represents a proxy for the mixing ratio λ . Using the combustion chamber temperature, the optimum lambda value for each operating condition is set.

Besides an exceedingly high electrical efficiency, a double-staged mixture cooling, including a low temperature circuit and a high temperature circuit, leads to an ideal usage of thermal power from the mixture heat.

Technical specification



Kraft-Wärme-Kopplung

avus800c
Erdgas MZ=80

Engine data			Engine utilities		
	Hz	400			
Mixture cooling to RPM	°C	50	Lubricate consumption	kg/h	0,16
ISO standard power (mech.)	1/min	1.500	Filling capacity lubricant min./max.	l	135
Arrangement of cylinders	kW	824	Filling capacity cooling water	l	56
Number of cylinders	V	16	Operating pressure (max.)	bar	2,5
Bore	mm	132	Cooling water recirculated quantity (min. / max.)	m³/h	39 / 60
Stroke	mm	160	Cooling water temperature (inflow)	°C	84
Swept volume	l	35	Cooling water temperature (exit)	°C	92
direction of rotation (look on balance wheel)	links		Balance (inflow/exit, max.)	K	8
compression ratio	ε	12,0 : 1	Mixture inflow temperature after damper (max.)	°C	50
average effective pressure	bar	18,8	Mixture cooling water, inflow temperature low	°C	40
average piston speed	m/s	8	temperature circuit (max.)		
			Mixture cooling water recirculated quantity low	m³/h	10
			temperature circuit (max.)		
Power data			Efficiencies		
	Hz	50			
Load	%	100		%	100 75 50
Ignition timing	grad	variabel	Electrical	%	42,3 41,1 38,7
ISO standard power (mech.)	kW	824	Mechanical	%	43,6 - -
Electrical power	kW el	800	Thermal	%	45,5 47,5 50,8
			Total (el. + th.)	%	87,8 88,6 89,5
Cooling water heat	kW	407			
Low temperature mixture heat	kW	56	Power number		0,93 0,87 0,76
High temperature mixture heat	kW	0			
Waste gas heat up to 120°C	kW	454	Mass flows and volume flows		
useable thermal power at 120°C	kW	861	Combustion air mass flow	kg/h	4.212
radiant heat of module (max.)	kW	94	Combustion air volume flow	Nm³/h	3.561
nominal power	kW	1.891	Supply air volume flow	m³/h	17.780
Fuel consumption (mech.)	kWh/kWh	2,29	Combustible mass flow	kg/h	149
Fuel consumption (el.)	kWh/kWh el	2,36	Combustible volume flow	m³/h	186
Temperatures and pressures			Waste gas mass flow, wet	kg/h	4.360
Waste gas temperature after turbine	°C	459	Waste gas mass flow, dry	kg/h	4.063
exhaus back pressure (max.)	mbar	50	Waste gas volume flow, wet	m³/h	3.429
Heating water return temperature (max.)	°C	70	Waste gas volume flow, dry	m³/h	3.080
Heating water flow temperature (max.)	°C	90	Heating water volume flow (max.)	m³/h	49,317
Pressure decrease heating circuit (max.)	mbar	200			
maximum backpressure at the air intake	mbar	5	Technical basic conditions		
Emission value at 5% residual oxygen			Power conditions acc. to DIN-ISO-3046		
NOx	mg/Nm³	< 500	Norm conditions: air pressure: 1000mbar,		
CO	mg/Nm³	< 300	air temperature: 25°C or 295 K, rel. humidity: 30%		
			Gasquality according "TR 0199-99-3017"		
			All data are related to full load engine running at denoted media temperatures and are subject to technical advancements.		
			Equipment as well as installation systems have to meet all MWM technical instructions.		
			When installed > 400 m and/or with intake air temperatures > 30 °C, the power reduction must be determined on a project-specific basis.		

Technical specification



Kraft-Wärme-Kopplung

avus800c
Erdgas MZ=80

Generator data

Manufacturer	Marelli	
Type	MJB 450 MB 4	
Power	kVA	990
Voltage	V	400
Frequency	Hz	50
Rated Speed	1/min	1500
Nominal current at Cos $\varphi = 0,8$	A	1.429
Cos φ	1	
Efficiency (full load) at Cos $\varphi = 1$	%	97,1
Efficiency (full load) at Cos $\varphi = 0,8$	%	96,17
Reactance Xd	p.u.	201
Reactance X'd	p.u.	18,8
Reactance X"d	p.u.	9,9
Mass moment of inertia	kgm ²	33,8
Stator circuit	Stern	
Ambient air temperature	°C	40
Protection class	IP 23	

The Cos Phi can be adjusted in between 0,8 inductive (lagging) and 0,95 capacitive (leading). The precise adjustment value however should be decided by the Utility company.

Main dimensions and weights

Module:			
Length (L)	mm	4.000	
Height (H)	mm	2.183	
Width (B)	mm	1.432	
Weight dry (approx.)	kg	7.550	
Control cabinet:			
Height (H)	mm	2.200	
Width (B)	mm	1.400	
Depth (T)	mm	600	
Weight (approx.)	kg	250	
Power switch cabinet:			
Height (H)	mm	2.100	
Width (B)	mm	600	
Depth (T)	mm	600	
Weight (approx.)	kg	120	

Modul:

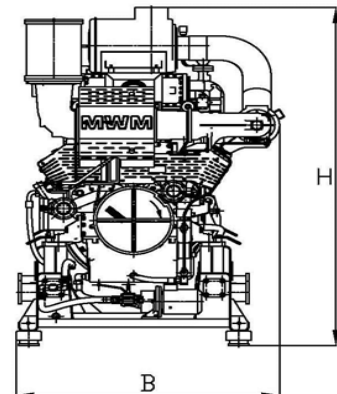
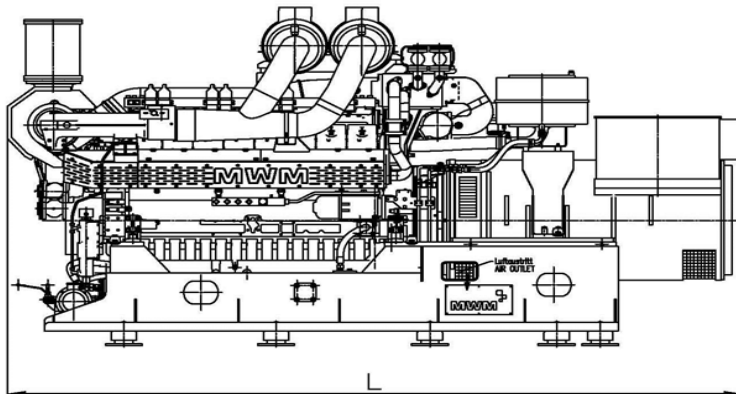

Control cabinet:

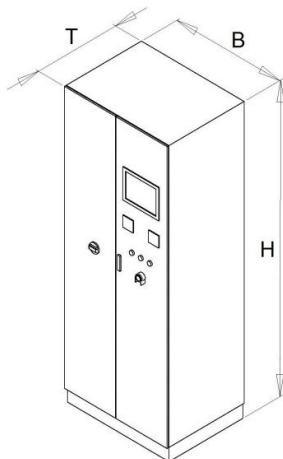

Power switch cabinet:

