

Illustration: may differ from specified module

Compact CHP ready for connection, mainly consisting of

- serially manufactured Industrial-Gas-Otto-engine
- air-cooled synchronous generator
- waste-gas heat exchanger integrated in primary cooling circuit
- oil reservoir with automatic oil feeding
- control cabinet with programmable controller and operating unit
- gas train

Integrated heat exchanger basket, mainly consisting of

- expansion tank in motor circuit and mixture circuit
- relief valve in motor circuit, mixture circuit and heater circuit
- filling valves, cleanout valves and exhaust valves
- plate heat exchanger
- pumps for motor circuit, mixture circuit and heater circuit
- 3-way mixing valve for return temperature increase

Water and gas connections are executed with compensators.

Motor and generator are connected through a pluggable elastic metal plastics coupler to compensate radial offset, axial offset or angular offset. It is mounted on a framework vibration-cushionedly. Furthermore the framework is uncoupled through oscillation decoupling elements.

The control cabinet is executed as a separate unit. All regulation and control functions as well as control elements are part of the control cabinet. Assisted by a menu-navigated display performance data and state data could be readed and adjusted easily.

The drive of the CHP is caused by a water-cooled, supercharged Otto-Gas-Engine. It is stationary engine designed for permanent operation. A micorprocessor-controlled ignition ensures an optimal adaption of the ignition point and the ignition energy to the gas quality (methane number).

Lambda regulation is carried out without a lambda sensor using a calculation program which sets the optimal lambda value for each operating mode using the actual output, charging pressure and mixture temperature values.

Besides an exceedingly high electrical efficiency, a double-staged mixture cooling, including a low temperature circuit and a high temperature circuit, leads to an ideal usage of thermal power from the mixture heat.

Technical specification



Kraft-Wärme-Kopplung

avus500b
Erdgas MZ=70

Engine data			Engine utilities		
	Hz	400			
Mixture cooling to	°C	45	Lubricate consumption	kg/h	0,20
RPM	1/min	1.500	Filling capacity lubricant min./max.	l	216
ISO standard power (mech.)	kW	657			
Arrangement of cylinders		V70°	Filling capacity cooling water	l	-
Number of cylinders		12	Operating pressure (max.)	bar	2,5
Bore	mm	135	Cooling water recirculated quantity (min. / max.)	m³/h	31,1
Stroke	mm	170	Cooling water temperature (inflow)	°C	75,1
Swept volume	l	29,2	Cooling water temperature (exit)	°C	80,9
			Balance (inflow/exit, max.)	K	5,8
direction of rotation (look on balance wheel)		links			
			Mixture inflow temperature after damper (max.)	°C	45
compression ratio	ε	12,5:1	Mixture cooling water, inflow temperature low	°C	40
average effective pressure	bar	18	temperature circuit (max.)		
average piston speed	m/s	8,5	Mixture cooling water recirculated quantity low	m³/h	15
			temperature circuit (max.)		
Power data			Efficiencies		
	Hz	50			
Load	%	100		%	100 75 50
Ignition timing	grad	variabel	Electrical	%	40,8 39,7 37,5
ISO standard power (mech.)	kW	657	Mechanical	%	42,1 - -
Electrical power	kW el	637	Thermal	%	46,4 47,5 49,3
			Total (el. + th.)	%	87,2 87,2 86,8
Cooling water heat	kW	278			
Low temperature mixture heat	kW	39	Power number		0,88 0,84 0,76
High temperature mixture heat	kW	116			
Waste gas heat up to 120°C	kW	331	Mass flows and volume flows		
useable thermal power at 120°C	kW	725			
radiant heat of module (max.)	kW	91	Combustion air mass flow	kg/h	3.290
nominal power	kW	1.562	Combustion air volume flow	Nm³/h	2.545
Fuel consumption (mech.)	kWh/kWh	2,38	Supply air volume flow	m³/h	16.311
Fuel consumption (el.)	kWh/kWh el	2,45			
			Combustible mass flow	kg/h	131
			Combustible volume flow	m³/h	164
Temperatures and pressures					
Waste gas temperature after turbine	°C	432	Waste gas mass flow, wet	kg/h	3.402
exhaus back pressure (max.)	mbar	60	Waste gas mass flow, dry	kg/h	3.150
			Waste gas volume flow, wet	m³/h	2.690
Heating water return temperature (max.)	°C	70	Waste gas volume flow, dry	m³/h	2.387
Heating water flow temperature (max.)	°C	90			
Pressure decrease heating circuit (max.)	mbar	200	Heating water volume flow (max.)	m³/h	41,527
maximum backpressure at the air intake	mbar	10	Technical basic conditions		
			Power conditions acc. to DIN-ISO-3046		
			Norm conditions: air pressure: 1000mbar,		
			air temperature: 25°C or 295 K, rel. humidity: 30%		
			Gasquality according "TA 1100-0110"		
			All data are related to full load engine running at denoted media temperatures and are subject to technical advancements.		
			Equipment as well as installation systems have to meet all Jenbacher technical instructions.		
			When installed > 500 m and/or with intake air temperatures > 30 °C, the power reduction must be determined on a project-specific basis.		
Emission value at 5% residual oxygen					
NOx	mg/Nm³	< 500			
CO	mg/Nm³	< 300			

Generator data				Main dimensions and weights			
Manufacturer	Leroy-Somer			Module:			
Type	LSAC 49.1 L9			Length (L)	mm	4.700	
Power	kVA	796		Height (H)	mm	2.300	
Voltage	V	400		Width (B)	mm	2.300	
Frequency	Hz	50		Weight dry (approx.)	kg	10.800	
Rated Speed	1/min	1500		Control cabinet:			
Nominal current at $\text{Cos } \varphi = 0,8$	A	1.149,29		Height (H)	mm	2.200	
$\text{Cos } \varphi$	1			Width (B)	mm	800	
Efficiency (full load) at $\text{Cos } \varphi = 1$	%	96,9		Depth (T)	mm	600	
Efficiency (full load) at $\text{Cos } \varphi = 0,8$	%	95,6		Weight (approx.)	kg	200	
Reactance X _d	p.u.	2,07		Power switch cabinet:			
Reactance X' _d	p.u.	0,13		Height (H)	mm	2.200	
Reactance X'' _d	p.u.	0,1		Width (B)	mm	600	
Mass moment of inertia	kgm ²	11,31		Depth (T)	mm	600	
Stator circuit	Stern			Weight (approx.)	kg	120	
Ambient air temperature	°C	40					
Protection class	IP 23						

$\text{Cos } \varphi$ has to be between 0,8 and 1,0 within the complete range of capacity. Only inductive power output permitted.

Modul:

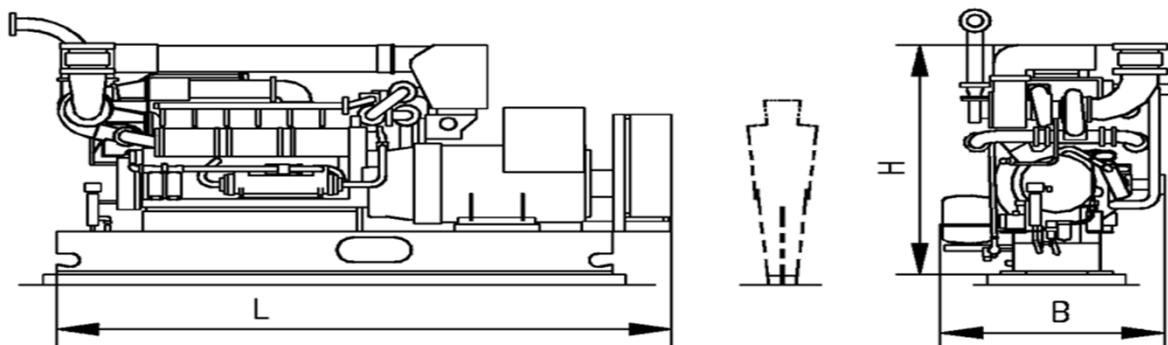

Control cabinet:

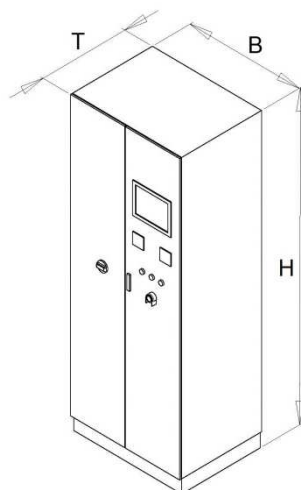

Power switch cabinet:

