

Illustration: may differ from specified module

**Compact CHP ready for connection, mainly consisting of**

- serially manufactured Industrial-Gas-Otto-engine
- air-cooled synchronous generator
- waste-gas heat exchanger integrated in primary cooling circuit
- oil reservoir with automatic oil feeding
- control cabinet with programmable controller and operating unit
- gas train

**Integrated heat exchanger basket, mainly consisting of**

- expansion tank in motor circuit and mixture circuit
- relief valve in motor circuit, mixture circuit and heater circuit
- filling valves, cleanout valves and exhaust valves
- plate heat exchanger
- pumps for motor circuit, mixture circuit and heater circuit
- 3-way mixing valve for return temperature increase

Water and gas connections are executed with compensators.

Motor and generator are connected through a pluggable elastic metal plastics coupler to compensate radial offset, axial offset or angular offset. It is mounted on a framework vibration-cushionedly. Furthermore the framework is uncoupled through oscillation decoupling elements.

The control cabinet is executed as a separate unit. All regulation and control functions as well as control elements are part of the control cabinet. Assisted by a menu-navigated display performance data and state data could be read and adjusted easily.

The drive of the CHP is caused by a water-cooled, supercharged Otto-Gas-Engine. It is stationary engine designed for permanent operation. A microprocessor-controlled ignition ensures an optimal adaption of the ignition point and the ignition energy to the gas quality (methane number).

Lambda regulation is carried out without a lambda sensor using a calculation program which sets the optimal lambda value for each operating mode using the actual output, charging pressure and mixture temperature values.

Besides an exceedingly high electrical efficiency, a double-staged mixture cooling, including a low temperature circuit and a high temperature circuit, leads to an ideal usage of thermal power from the mixture heat.

# Technical specification



Kraft-Wärme-Kopplung

avus500a

Biogas 60% CH<sub>4</sub>, 40% CO<sub>2</sub>

Engine data			Engine utilities		
	Hz	400			
Mixture cooling to RPM	°C	55	Lubricate consumption	kg/h	0,16
ISO standard power (mech.)	1/min	1.500	Filling capacity lubricant min./max.	l	216
Arrangement of cylinders	kW	544	Filling capacity cooling water	l	-
Number of cylinders		V 70°	Operating pressure (max.)	bar	2,5
Bore	mm	12	Cooling water recirculated quantity (min. / max.)	m <sup>3</sup> /h	25,2
Stroke	mm	135	Cooling water temperature (inflow)	°C	79,4
Swept volume	l	170	Cooling water temperature (exit)	°C	86,1
		29,2	Balance (inflow/exit, max.)	K	6,7
direction of rotation (look on balance wheel)		links	Mixture inflow temperature after damper (max.)	°C	55
compression ratio	ε	16:1	Mixture cooling water, inflow temperature low	°C	50
average effective pressure	bar	14,9	temperature circuit (max.)		
average piston speed	m/s	8,5	Mixture cooling water recirculated quantity low	m <sup>3</sup> /h	15
			temperature circuit (max.)		
Power data			Efficiencies		
	Hz	50			
Load	%	100		%	100 75 50
Ignition timing	grad	variabel	Electrical	%	41,1 39,7 37,1
ISO standard power (mech.)	kW	544	Mechanical	%	42,4 41,1 38,7
Electrical power	kW el	527	Thermal	%	41,1 42,7 44,5
			Total (el. + th.)	%	82,2 82,4 81,6
Cooling water heat	kW	251	Power number		1,00 0,93 0,83
Low temperature mixture heat	kW	29			
High temperature mixture heat	kW	66			
Waste gas heat up to 180°C	kW	210			
useable thermal power at 180°C	kW	527			
radiant heat of module (max.)	kW	89			
nominal power	kW	1.282			
Fuel consumption (mech.)	kWh/kWh	2,36			
Fuel consumption (el.)	Wh/kWh el	2,43			
Temperatures and pressures			Mass flows and volume flows		
Waste gas temperature after turbine	°C	410	Combustion air mass flow	kg/h	2.706
exhaus back pressure (max.)	mbar	60	Combustion air volume flow	Nm <sup>3</sup> /h	2.094
			Supply air volume flow	m <sup>3</sup> /h	20.539
Heating water return temperature (max.)	°C	75	Combustible mass flow	kg/h	284
Heating water flow temperature (max.)	°C	95	Combustible volume flow	m <sup>3</sup> /h	214
Pressure decrease heating circuit (max.)	mbar	200	Waste gas mass flow, wet	kg/h	2.936
			Waste gas mass flow, dry	kg/h	2.728
maximum backpressure at the air intake	mbar	10	Waste gas volume flow, wet	m <sup>3</sup> /h	2.282
			Waste gas volume flow, dry	m <sup>3</sup> /h	2.033
			Heating water volume flow (max.)	m <sup>3</sup> /h	30,186
Emission value at 5% residual oxygen			Technical basic conditions		
NOx	mg/Nm <sup>3</sup>	< 500	Power conditions acc. to DIN-ISO-3046		
CO	mg/Nm <sup>3</sup>	< 1.000	Norm conditions: air pressure: 1000mbar,		
			air temperature: 25°C or 295 K, rel. humidity: 30%		
			Gasquality according "TA 1000-0300"		
			All data are related to full load engine running at denoted		
			media temperatures and are subject to technical advancements.		
			Equipment as well as installation systems have to meet all		
			Jenbacher technical instructions.		
			When installed > 500 m and/or with intake air temperatures > 30 °C,		
			the power reduction must be determined on a project-specific basis.		

# Technical specification



Kraft-Wärme-Kopplung

avus500a

Biogas 60% CH<sub>4</sub>, 40% CO<sub>2</sub>

## Generator data

Manufacturer	Leroy-Somer	
Type	LSAC 49.1 L9	
Power	kVA	792
Voltage	V	400
Frequency	Hz	50
Rated Speed	1/min	1500
Nominal current at Cos φ = 0,8	A	939
Cos φ		1
Efficiency (full load) at Cos φ = 1	%	96,9
Efficiency (full load) at Cos φ = 0,8	%	95,7
Reactance X <sub>d</sub>	p.u.	1,71
Reactance X' <sub>d</sub>	p.u.	0,11
Reactance X'' <sub>d</sub>	p.u.	0,09
Mass moment of inertia	kgm <sup>2</sup>	11,31
Stator circuit		Stern
Ambient air temperature	°C	40
Protection class		IP 23

The Cos Phi can be adjusted in between 0,8 inductive (lagging) and 0,95 capacitive (leading). The precise adjustment value however should be decided by the Utility company.

## Main dimensions and weights

<b>Module:</b>			
Length (L)	mm	4.700	
Height (H)	mm	2.300	
Width (B)	mm	2.300	
Weight dry (approx.)	kg	9.100	
<b>Control cabinet:</b>			
Height (H)	mm	2.200	
Width (B)	mm	1.000	
Depth (T)	mm	600	
Weight (approx.)	kg	200	
<b>Power switch cabinet:</b>			
Height (H)	mm	2.200	
Width (B)	mm	600	
Depth (T)	mm	600	
Weight (approx.)	kg	120	

## Modul:

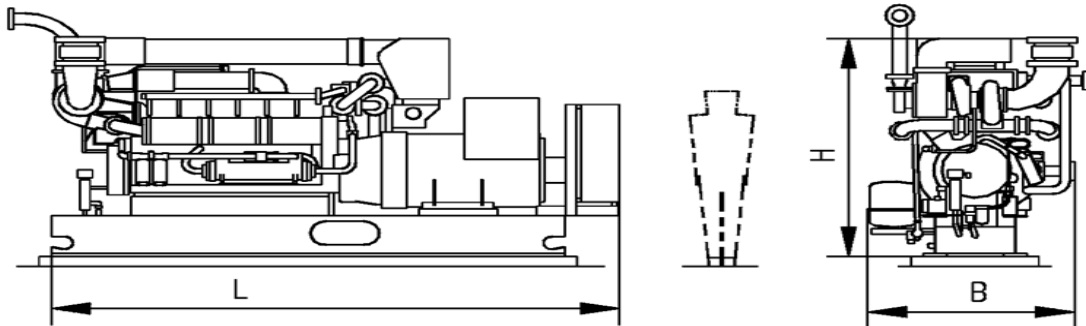

## Control cabinet:

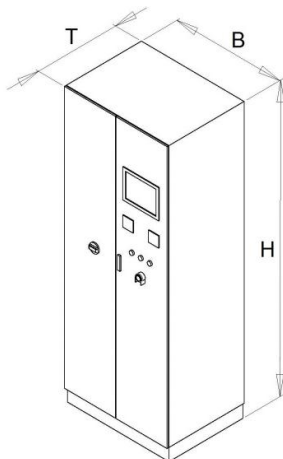

## Power switch cabinet:

