

Illustration: may differ from specified module

**Compact CHP ready for connection, mainly consisting of**

- serially manufactured Industrial-Gas-Otto-engine
- air-cooled synchronous generator
- waste-gas heat exchanger integrated in primary cooling circuit
- oil reservoir with automatic oil feeding
- control cabinet with programmable controller and operating unit
- gas train

**Integrated heat exchanger basket, mainly consisting of**

- expansion tank in motor circuit and mixture circuit
- relief valve in motor circuit, mixture circuit and heater circuit
- filling valves, cleanout valves and exhaust valves
- plate heat exchanger
- pumps for motor circuit, mixture circuit and heater circuit
- 3-way mixing valve for return temperature increase

Water and gas connections are executed with compensators.

Motor and generator are connected through a pluggable elastic metal plastics coupler to compensate radial offset, axial offset or angular offset. It is mounted on a framework vibration-cushionedly. Furthermore the framework is uncoupled through oscillation decoupling elements.

The control cabinet is executed as a separate unit. All regulation and control functions as well as control elements are part of the control cabinet. Assisted by a menu-navigated display performance data and state data could be read and adjusted easily.

The drive of the CHP is caused by a water-cooled, supercharged Otto-Gas-Engine. It is stationary engine designed for permanent operation. A microprocessor-controlled ignition ensures an optimal adaption of the ignition point and the ignition energy to the gas quality (methane number).

Lambda regulation is carried out without a lambda sensor using a calculation program which sets the optimal lambda value for each operating mode using the actual output, charging pressure and mixture temperature values.

Besides an exceedingly high electrical efficiency, a double-staged mixture cooling, including a low temperature circuit and a high temperature circuit, leads to an ideal usage of thermal power from the mixture heat.

# Technical specification



Kraft-Wärme-Kopplung

avus1000a

Biogas 60% CH<sub>4</sub>, 40% CO<sub>2</sub>

Engine data			Engine utilities		
	Hz	400			
Mixture cooling to	°C	55	Lubricate consumption	kg/h	0,33
RPM	1/min	1.500	Filling capacity lubricant min./max.	l	342
ISO standard power (mech.)	kW	1.095			
Arrangement of cylinders		V 70°	Filling capacity cooling water	l	-
Number of cylinders		20	Operating pressure (max.)	bar	2,5
Bore	mm	135	Cooling water recirculated quantity (min. / max.)	m <sup>3</sup> /h	52,4
Stroke	mm	170	Cooling water temperature (inflow)	°C	80,5
Swept volume	l	48,67	Cooling water temperature (exit)	°C	86,2
			Balance (inflow/exit, max.)	K	5,7
direction of rotation (look on balance wheel)		links			
			Mixture inflow temperature after damper (max.)	°C	55
compression ratio	ε	12,5	Mixture cooling water, inflow temperature low	°C	50
average effective pressure	bar	18,0	temperature circuit (max.)		
average piston speed	m/s	8,5	Mixture cooling water recirculated quantity low	m <sup>3</sup> /h	25
			temperature circuit (max.)		
Power data			Efficiencies		
	Hz	50			
Load	%	100		%	100 75 50
Ignition timing	grad	variabel	Electrical	%	40,9 39,7 37,5
ISO standard power (mech.)	kW	1.095	Mechanical	%	42,0 40,9 38,9
Electrical power	kW el	1.067	Thermal	%	41,8 44,1 46,5
			Total (el. + th.)	%	82,7 83,8 84
Cooling water heat	kW	310			
Low temperature mixture heat	kW	81	Power number	0,98	0,90 0,81
High temperature mixture heat	kW	178			
Waste gas heat up to 180°C	kW	479	Mass flows and volume flows		
useable thermal power at 180°C	kW	1.089			
radiant heat of module (max.)	kW	160	Combustion air mass flow	kg/h	5.176
nominal power	kW	2.606	Combustion air volume flow	Nm <sup>3</sup> /h	4.004
Fuel consumption (mech.)	kWh/kWh	2,38	Supply air volume flow	m <sup>3</sup> /h	41.349
Fuel consumption (el.)	kWh/kWh el	2,44			
			Combustible mass flow	kg/h	575
			Combustible volume flow	m <sup>3</sup> /h	434
Temperatures and pressures					
Waste gas temperature after turbine	°C	450	Waste gas mass flow, wet	kg/h	5.642
exhaus back pressure (max.)	mbar	60	Waste gas mass flow, dry	kg/h	5.221
			Waste gas volume flow, wet	m <sup>3</sup> /h	4.387
Heating water return temperature (max.)	°C	75	Waste gas volume flow, dry	m <sup>3</sup> /h	3.881
Heating water flow temperature (max.)	°C	95			
Pressure decrease heating circuit (max.)	mbar	200	Heating water volume flow (max.)	m <sup>3</sup> /h	62,377
maximum backpressure at the air intake	mbar	10	Technical basic conditions		
			Power conditions acc. to DIN-ISO-3046		
			Norm conditions: air pressure: 1000mbar,		
			air temperature: 25°C or 295 K, rel. humidity: 30%		
			Gasquality according "TA 1000-0300"		
			All data are related to full load engine running at denoted		
			media temperatures and are subject to technical advancements.		
			Equipment as well as installation systems have to meet all		
			Jenbacher technical instructions.		
			When installed > 500 m and/or with intake air temperatures > 30 °C,		
			the power reduction must be determined on a project-specific basis.		
Emission value at 5% residual oxygen					
NOx	mg/Nm <sup>3</sup>	< 500			
CO	mg/Nm <sup>3</sup>	< 1.000			

# Technical specification



Kraft-Wärme-Kopplung

avus1000a

Biogas 60% CH<sub>4</sub>, 40% CO<sub>2</sub>

## Generator data

Manufacturer	STAMFORD	
Type	PE 734 E	
Power	kVA	1.710
Voltage	V	400
Frequency	Hz	50
Rated Speed	1/min	1500
Nominal current at Cos φ = 0,8	A	1.908
Cos φ		1
Efficiency (full load) at Cos φ = 1	%	97,4
Efficiency (full load) at Cos φ = 0,8	%	96,6
Reactance X <sub>d</sub>	p.u.	2,06
Reactance X' <sub>d</sub>	p.u.	0,12
Reactance X'' <sub>d</sub>	p.u.	0,09
Mass moment of inertia	kgm <sup>2</sup>	44,49
Stator circuit	Stern	
Ambient air temperature	°C	40
Protection class	IP 23	

The Cos Phi can be adjusted in between 0,8 inductive (lagging) and 0,95 capacitive (leading). The precise adjustment value however should be decided by the Utility company.

## Main dimensions and weights

<b>Module:</b>		
Length (L)	mm	5.700
Height (H)	mm	2.300
Width (B)	mm	1.900
Weight dry (approx.)	kg	11.600
<b>Control cabinet:</b>		
Height (H)	mm	2.200
Width (B)	mm	1.000
Depth (T)	mm	600
Weight (approx.)	kg	240
<b>Power switch cabinet:</b>		
Height (H)	mm	2.200
Width (B)	mm	600
Depth (T)	mm	600
Weight (approx.)	kg	120

## Modul:

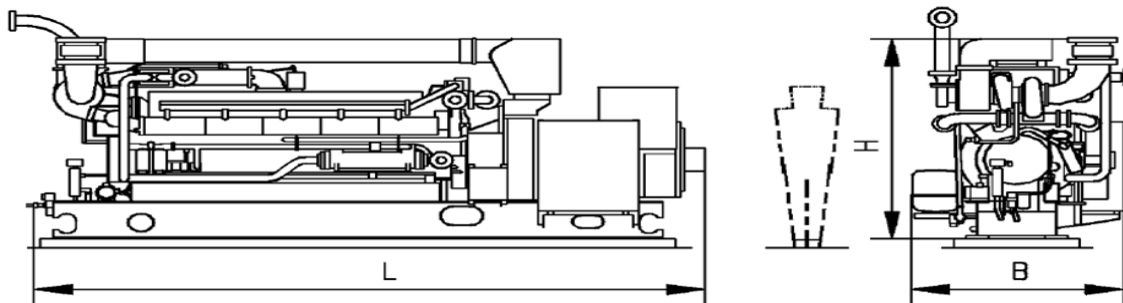

## Control cabinet:

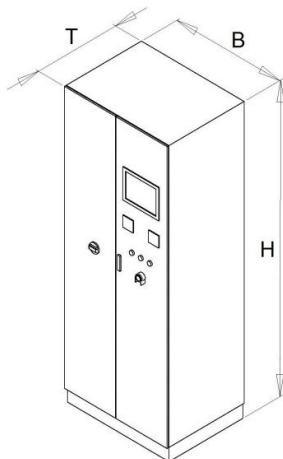

## Power switch cabinet:

